



NEW HOLLAND

L150 L160 L170 L175 TIER 3A

MAIN SPECIFICATIONS

 PERFORMANCE	L150	L160	L170	L175
SAE operating capacity (kg)	612	726	801	907
Tipping load (kg)	1166	1601	1601	1814
Bucket breakout (kg)	1590	1687	1687	1956
Boom breakout (kg)	1089	1286	1286	1362
Boom raising time - loaded (sec)	3.3	3.0	2.7	3.1
Boom lowering time - empty (sec)	1.9	3.0	2.3	2.1
Bucket dump time - loaded (sec)	1.0	2.0	1.7	2.3
SAE operating weight (kg)	2045	2510	2515	2826
ENGINE TIER 3A				
Engine power ISO 14396/ECE R120 (kW/hp)	28/37	34/46	39/52	45/60
Make/Model	ISM/N843H	ISM/N844	ISM/N844T	ISM/N844LT Turbo
Displacement (l)	1.5	2.0	2.0	2.2
Cylinders (n°)	3	4	4	4
Diesel tank capacity (l)	33	54	54	62
<i>The engine complies with 97/68/EC standards Tier 3A</i>				
HYDRAULIC SYSTEM				
Pump type	Gear	Gear	Gear	Gear
Pump capacity (l/min)	44	57	65	65
Max. pressure (bar)	172	172	172	172-178
Hi-Flow (l/min)	-	-	114.7	114.7
Hydraulic oil capacity (l)	18.9	32.6	32.6	32.6
TRANSMISSION				
Type	Hydrostatic	Hydrostatic	Hydrostatic	Hydrostatic
Pumps and motors	Axial pistons	Axial pistons	Axial pistons	Axial pistons
Max low/high speed (km/h)	-/11.8	-/11.8	-/11.8	9.5/16.1

UNIQUE COMMON FEATURES OF THE NEW HOLLAND SKID-STEER LOADERS

Plus factors of "Super Boom" skid-steers with patented mechanism

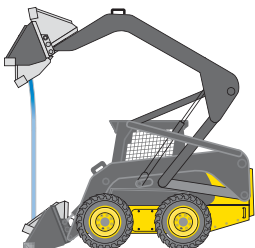

- The low centre of gravity reduces the risk of tipping, giving higher lifting capacity
- There are no structural obstacles, so rear visibility is best-in-class.
- Vertical lifting means maximum reach at maximum height
- Bucket remains level for less spillage



BUILT AROUND YOU

MAIN DIMENSIONS

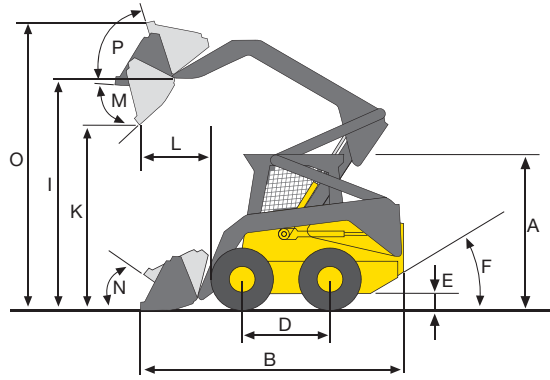
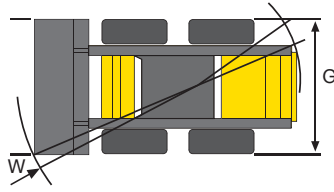

	A mm	B mm	D mm	E mm	F (°)	G mm	I mm	K mm	P (°)	M (°)	N (°)	W mm	L mm	O mm
L150	1865	3050	950	210	25	1525	2905	2332	76	45	36	3226	640	3560
L160	1900	3175	1080	190	23	1670	2934	2339	76	45	37	3403	740	3560
L170	1900	3175	1080	190	23	1670	2934	2339	76	45	37	3403	740	3560
L175	1930	3290	1080	210	25	1800	3040	2420	76	43	37	3556	740	3720



L160, L170 & 175 OPTIONAL PILOT CONTROL VERSION

- COMFORTABLE, ENERGY-SAVING OPERATOR POSITION
- COMPLETE MACHINE CONTROLLABILITY
- SMOOTHER, SAFER MOVEMENTS

AT YOUR OWN DEALERSHIP

The information contained in this brochure is intended to be a general nature only. The NEW HOLLAND KOBELCO CONSTRUCTION MACHINERY S.p.A. company may at any time and from time to time, for technical or other necessary reasons, modify any of the details or specifications of the product described in this brochure. Illustrations do not necessarily show products in standard conditions. The dimensions, weights and capacities shown herein, as well as any conversion data used, are approximate only and are subject to variations within normal manufacturing techniques.

Published by NEW HOLLAND KOBELCO CONSTRUCTION MACHINERY S.p.A.
Printed in Italy - LEADER Firenze - Cod. 73301 446GB - Printed 02/08

Printed on recycled paper
CoC-FSC 000010 CQ Mixed sources



ELEMENTAL
CHLORINE
FREE
GUARANTEED

FIAT
GROUP

NEW HOLLAND
CONSTRUCTION

BUILT AROUND YOU

www.newholland.com