



NEW HOLLAND

W50_{BTC} W60_{BTC} W70_{BTC} W80_{BTC}



	W50BTC	W60BTC	W70BTC	W80BTC
ENGINE POWER	40 kW - 54 hp	48 kW - 64 hp	55 kW - 74 hp	61 kW - 82 hp
MAXIMUM OPERATING WEIGHT	4 760 kg	5 085 kg	5 580 kg	5 930 kg
BUCKET CAPACITY	0.70 - 0.80 m ³	0.80 - 0.90 m ³	0.90 - 1.00 m ³	1.00 - 1.20 m ³



NEW HOLLAND

CONSTRUCTION

BUILT AROUND YOU

W50BTC/W60BTC/W70BTC/W80BTC



MODERN, SPACIOUS AND ERGONOMIC ROPS/FOPS CAB

- With all round 360° visibility. Front and rear wipers, heater and defroster for easy operations in all weather conditions. All controls are ergonomically positioned; adjustable steering column and retractable seat belt.
- Instrument panel with analogic gauges which monitor engine oil temperature and fuel level. The hourmeter is integrated in the instrument cluster.



JOYSTICK

- Pilot controlled joystick:
 - To operate arm and bucket
 - Integrating F/N/R button and speed shift selector



NEW CNH TIER 3A ENGINE

- The new, modern, turbocharged, water cooled, low consumption and low emission CNH engine complies with 97/68/EC Standards Tier 3A.
- To enhance cooling and cleaning efficiency, water and hydraulic oil aluminium type coolers, are now mounted in parallel and repositioned on the rear left side of the engine compartment.



HYDROSTATIC TRANSMISSION & AXLES

- Fully hydrostatic transmission with two speeds variable displacement hydraulic motor:
 - 1st speed: 0 - 6 km/h
 - 2nd speed: 0 - 20 km/h
- The hydraulic motor drives directly the front axle and effects the rear one by joint shaft.
- Front axle is equipped with standard Limited Slip Differential and it is fixed. Rear axle oscillates +/- 12°.
- Both axles have planetary reduction outboard.

BRAKES

Hydraulic, calliper brake on front axle input flange, effecting rear axle by joint shaft. One left brake/inch pedal, activating reduces hydraulic flow to the transmission and than applies hydraulic pressure on calliper brake. Parking brake: mechanical, on front axle input flange and joint shaft.

HIGH SPEED version (W60BTC/W70BTC/W80BTC) includedes as standard:

- two additional wet disc brakes on front axle, close to planetaries.
- Limited slip differential also on rear axle
- Speedometer

Max Travel speed up to 35 km/h





OUTSTANDING STABILITY

■ In both bucket and fork applications even at 40° articulation thanks to the long wheel base, the weight distribution, the low centre of gravity and rear axle oscillation.

LOADER ARMS

- MONO BOOM parallel linkage
 - torsion resistant, precision welded box design
 - excellent visibility to the front tool and quick hitch
 - precise parallel lift throughout the cycle (+/-1°)
 - constant high breakout force and fast dumping speeds



STANDARD HYDRAULIC QUICK-HITCH

- - versatile in all kinds of applications
- compatible to the New Holland Skid Steer Loaders and Compact Track Loaders coupler norm
- quick and easy changeover of forks, multi-purpose and 4 in 1 buckets from inside the cab



ACCESSIBILITY

- The layout of main components and their accessibility has been even improved, if compared with previous models, for an easier maintenance and serviceability from ground level.



W50BTC/W60BTC

SPECIFICATIONS



ENGINE TIER 3A - W50BTC

Engine power (ISO ECE R120)40 kW/54 hp
 Net engine power (SAE J1349).....38 kW/51 hp
 Engine speed2300 rpm
 Make and model.....CNH F5C E9454C
 Type:.....diesel, watercooled, turbo, direct injection
 Number of cylinders4
 Bore x stroke / displacement99 x 104 mm / 3.2 l
 Max torque at 1250 rpm240 Nm
 Air filterdry type with warning indicator
The engine conforms to 97/68/EC Standards Tier 3A.



ENGINE TIER 3A - W60BTC

Engine power (ISO ECE R120)48 kW/64 hp
 Net engine power (SAE J1349).....45 kW/60 hp
 Engine speed2300 rpm
 Make and model.....CNH F5C E9454G
 Type:.....diesel, watercooled, turbo, direct injection
 Number of cylinders4
 Bore x stroke / displacement99 x 104 mm / 3.2 l
 Max torque at 1250 rpm290 Nm
 Air filterdry type with warning indicator
The engine conforms to 97/68/EC Standards Tier 3A.



ENGINE TIER 3A - W70BTC

Engine power (ISO ECE R120)55 kW/74 hp
 Net engine power (SAE J1349).....51 kW/68 hp
 Engine speed2500 rpm
 Make and modelCNH F5C E9454E
 Type:.....diesel, watercooled, turbo, direct injection
 Number of cylinders4
 Bore x stroke / displacement99 x 104 mm / 3.2 l
 Max torque at 1250 rpm280 Nm
 Air filterdry type with warning indicator
The engine conforms to 97/68/EC Standards Tier 3A.



ENGINE TIER 3A - W80BTC

Engine power (ISO ECE R120)61 kW/82 hp
 Net engine power (SAE J1349).....57 kW/76 hp
 Engine speed2500 rpm
 Make and modelCNH F5C E5454B
 Type:.....diesel, watercooled, turbo, direct injection
 Number of cylinders4
 Bore x stroke / displacement99 x 104 mm / 3.2 l
 Max torque at 1250 rpm310 Nm
 Air filterdry type with warning indicator
The engine conforms to 97/68/EC Standards Tier 3A.



ELECTRICAL SYSTEM ALL MODELS

Operating voltage12 V
 Alternator95 A
 Battery1 x 95 Ah



HYDRAULIC SYSTEM - W50BTC

Typegear type pump for implement and steering,
 open centre circuit, pressure/flow compensated.
 3rd hydraulic function for 4-in-1 bucket.
 Max. flow52 l/min
 max. working pressure250 bar



HYDRAULIC SYSTEM - W60BTC

Typegear type pump for implement and steering,
 open centre circuit, pressure/flow compensated.
 3rd hydraulic function for 4-in-1 bucket.
 Max. flow74 l/min
 max. working pressure270 bar



HYDRAULIC SYSTEM - W70BTC

Typegear type pump for implement and steering,
 open centre circuit, pressure/flow compensated.
 3rd hydraulic function for 4-in-1 bucket.
 Max. flow70 l/min
 max. working pressure270 bar



HYDRAULIC SYSTEM - W80BTC

Typegear type pump for implement and steering,
 open centre circuit, pressure/flow compensated.
 3rd hydraulic function for 4-in-1 bucket.
 Max. flow80 l/min
 max. working pressure270 bar



TRANSMISSION ALL MODELS

Type.....hydrostatic transmission, (with automatic power regulation),
 inching pedal (slow approach), directional and gear change
 integrated into the loader control handle.
 Permanent 4 wheel drive.

Forward/ Reverse speeds km/h

1°0-6.0

2°0-20.0

Optional HIGH SPEED version available for
 W60BTC/W70BTC/W80BTC

1° **HIGH SPEED**0-5.5

2° **HIGH SPEED**0-16.5

plus 2° **HIGH SPEED** (mechanical gear section for travelling) ..0-35.0



AXLES - ALL MODELS

All wheel drive with planetaries outboard
 Front axle rigid.....limited slip differential as standard
 Real axle oscillating±12°
 Optional limited slip differential
 Standard Limited slip differential on **HIGH SPEED** version
 (W60BTC/W70BTC/W80BTC)

W70BTC/W80BTC



BRAKES - ALL MODELS

Hydrostatic Brake.....(on Transmission) actuated over inch brake pedal, in combination with Service Brake
 Service Brake.....hydraulically actuated dry disk type, direct on front axle input flange and on joint shaft
HIGH SPEED version (W60BTC/W70BTC/W80BTC) has two additional wet disc brakes on front axle, close to planetaries.
 Parking brakes....mechanical, on front axle input flange and joint shaft



STEERING

TypeORBITROL
 Articulation angle±40°
 Turning radius - bucket corner:
 - W50BTC.....4.3 m
 - W60BTC.....4.5 m
 - W70BTC.....4.6 m
 - W80BTC.....4.7 m



CAB AND CONTROLS

- Modern, spacious and ergonomic
- All round 360° visibility
- ROPS/FOPS
- Radio pre-equipment
- Adjustable steering column
- Heater and defroster
- Fully adjustable, cloth suspension seat
- Key start
- Foot throttle
- Electronic speed shift control and F/N/R switch in loader control handle
- Retractable seat belt
- Cup holder
- Storage tray
- Sun screen front and rear
- Dome light
- Wipers front and rear
- 12-volt auxiliary power
- External rearview mirrors
- Coat hook



CAPACITIES

Engine	litres
- Lubrication oil.....	8.5
- Cooling system.....	16.5
- Fuel tank.....	100.0
- W50B Front & Rear axle (each).....	8.9
Front Axle (W60B/70B/80B).....	9.2
Rear Axle (W60B/70B/80B).....	9.4
Rear Axle (With high Speed W60B/70B/80B).....	10.2
Total Hydraulic system: W50B-W60B-W70B-W80B.....	56-67-67-74



W50BTC/W60BTC/W70BTC/W80BTC

DIMENSIONS - OPERATING WEIGHT

WITH MULTIPURPOSE BUCKET		W50BTC	W60BTC	W70BTC	W80BTC	
A	Overall length	mm	5330	5435	5600	5755
B	Cab height	mm	2710	2825	2815	2805
D	Width over tyres	mm	1860	1910	1905	1980
E	Dump clearance	mm	2530	2585	2620	2635
F	Bucket dumping reach	mm	825	790	845	890
G	Maximum pin height	mm	3245	3300	3385	3460
H	Digging depth	mm	90	60	85	90
I	Wheelbase	mm	2180	2250	2350	2350
J	Tread width	mm	1480	1525	1525	1570
K	Ground clearance at disc brake	mm	330	330	330	330
	Max. Operating weight (incl add. CW)	kg	4760	5085	5580	5930
Q	Pin high in carry position	mm	370	370	370	370
R	Ground clearance under joint shaft	mm	415	415	415	415

PERFORMANCE

WITH MULTIPURPOSE BUCKET		W50BTC	W60BTC	W70BTC	W80BTC	
	Standard bucket capacity (1.8 density)	m ³	0.7	0.8	0.9	1.1
	Breakout	daN	3805	4550	4620	5435
	Tipping load - Straight ISO	mm	3565	3745	4530	4680
	Tipping load - turned to 40° ISO	kg	3130	3305	3875	3975
C	Bucket width	kg	1900	2050	2050	2100
	Lift capacity at ground level (hydr)	daN	4250	5520	5070	6080

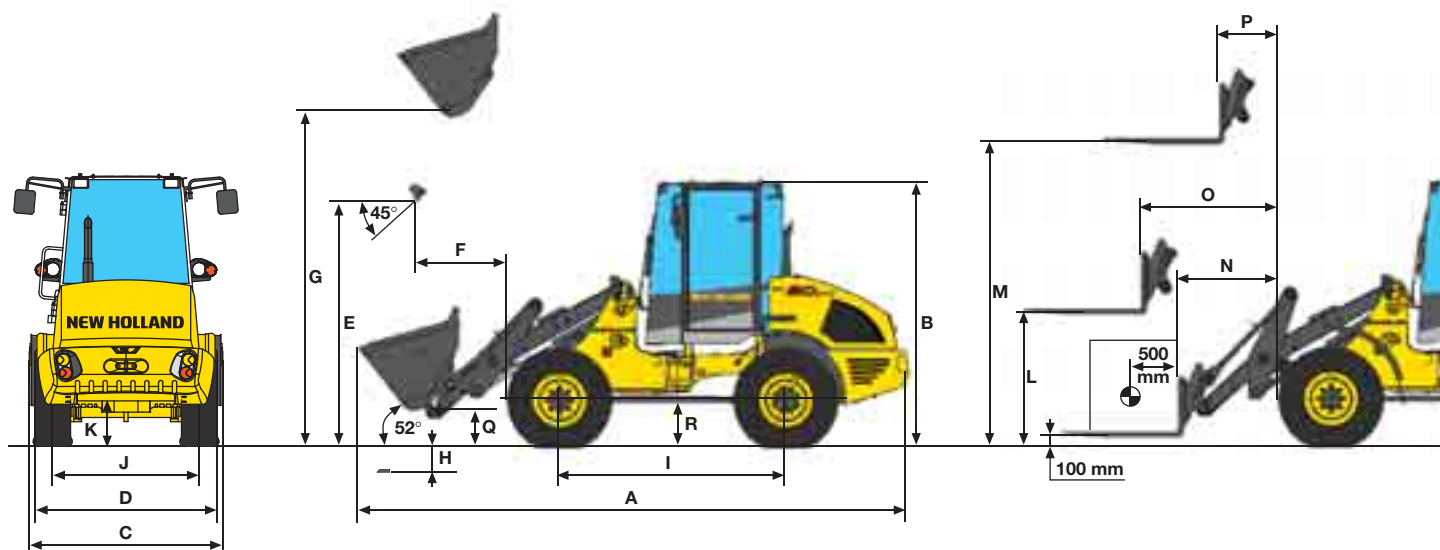

DIMENSIONS - OPERATING WEIGHT

WITH PALLET FORKS		W50BTC	W60BTC	W70BTC	W80BTC	
	Fork length	mm	1200	1200	1200	1200
	Fork support width	mm	1450	1450	1450	1450
	Weight	kg	370	370	370	370
L	Height at maximum reach	mm	1380	1440	1490	1490
M	Maximum height	mm	3040	3100	3180	3260
N	Ground reach	mm	850	740	760	820
O	Maximum reach	mm	1330	1270	1300	1350
P	Reach at maximum height	mm	595	535	570	555
	Payload flat terrain (80%) - turned	kg	1640	1780	2120	2220
	Payload rough terrain (60%) - turned	kg	1230	1340	1590	1660
	Operating weight (incl add. CW)	kg	4785	5040	5520	5835

STANDARD EQUIPMENT

- 3rd hydraulic function (for 4-in-1 bucket, add hydr. attachments)
- 4 wheel drive
- Adjustable steering column
- Air filter warning
- Alarm and warning lights
- Bucket equipment control lever with F/N/R and speed shift selector
- Cab air filter
- Dry disc service and parking brake
- Electrical circuit protection
- Forward or reverse drive indicator
- Front and rear wide fenders
- Front halogen flood headlights
- Full suspension and fully adjustable bucket-type seat
- Heated cab
- HIGH SPEED version available for W60BTC, W70BTC, W80BTC, includes:
 - limited slip differential on rear axle
 - two additional wet disc brakes on front axle;
 - speedometer
- Hydraulic cooler
- Hydraulic quick coupler (SSL compatible)
- Hydraulic return filter
- Horn
- Hourmeter
- Inching pedal
- Planetary reductions outboard
- Retractable seat belt
- ROPS/FOPS cab
- Tail flash and stop lights combined

OPTIONAL

- Additional headlight
- Anti-theft device
- Automatic return to dig
- Back-up alarm
- Heavier counterweight (check your country configuration!)
- Hinge window latch
- High performance heating with air conditioning
- Hose rupture valves on loader arms (Not in combination with LTS)
- Limited slip differential rear axle (Standard on HIGH SPEED versions)
- LTS Load Transportation Stabilisator (Not in combination with safety valves)
- Radio-cassette player
- Rotating beacon
- Working lights front & rear

Note: standard and optional equipment may vary by country. Consult your NEW HOLLAND dealer for specific details.

BUCKETS

MODEL	SAE CAPACITY / m ³	WIDTH / mm	WEIGHT / kg
W50BTC	0.70	1900	265
W50BTC	0.80	1900	295
W60BTC	0.80	2050	315
W60BTC	0.90	2050	335
W70BTC	0.90	2050	335
W70BTC	1.00	2100	365
W80BTC	1.00	2100	365
W80BTC	1.10	2100	370
W80BTC	1.20	2100	410

NEW HOLLAND. THE POWER OF A GLOBAL BRAND

New Holland is a global brand with a key position in the Construction Equipment business. It supplies a **complete range of 13 product lines and 80 basic models** split into **Compact line** and **Heavy line**. It operates in all the main markets, such as **Europe, North and Latin America, Africa, Asia and Middle East** with the same technology and under the same logo and brand. It manufactures **durable, safe and productive** machines aimed at supporting customers in developing their own business. **Dealers are company partners**. They play an important role to support the brand in their territories through intense professional relationship with Customers. New Holland is reinforced by its **global alliance with Kobelco**: world leader in hydraulic excavator technology.



AT YOUR OWN DEALERSHIP

The information contained in this brochure is intended to be a general nature only. The NEW HOLLAND KOBELCO CONSTRUCTION MACHINERY S.p.A. company may at any time and from time to time, for technical or other necessary reasons, modify any of the details or specifications of the product described in this brochure. Illustrations do not necessarily show products in standard conditions. The dimensions, weights and capacities shown herein, as well as any conversion data used, are approximate only and are subject to variations within normal manufacturing techniques.

Published by NEW HOLLAND KOBELCO CONSTRUCTION MACHINERY S.p.A.
Printed in Italy - LEADER Firenze - Cod. 73301 455GB - Printed 04/08

Printed on recycled paper
CoC-FSC 000010 CQ Mixed sources



ELEMENTAL
CHLORINE
FREE
GUARANTEED

FIAT
GROUP



BUILT AROUND YOU

www.newholland.com